

Ford Transit

Rahmen Tagfahrleuchte

Daytime running lights frame

Teilenummer / Part number

MSD.FO91.06.01TFL

Änderungen des Lieferumfangs vorbehalten/Equipment supplied is subject to alteration

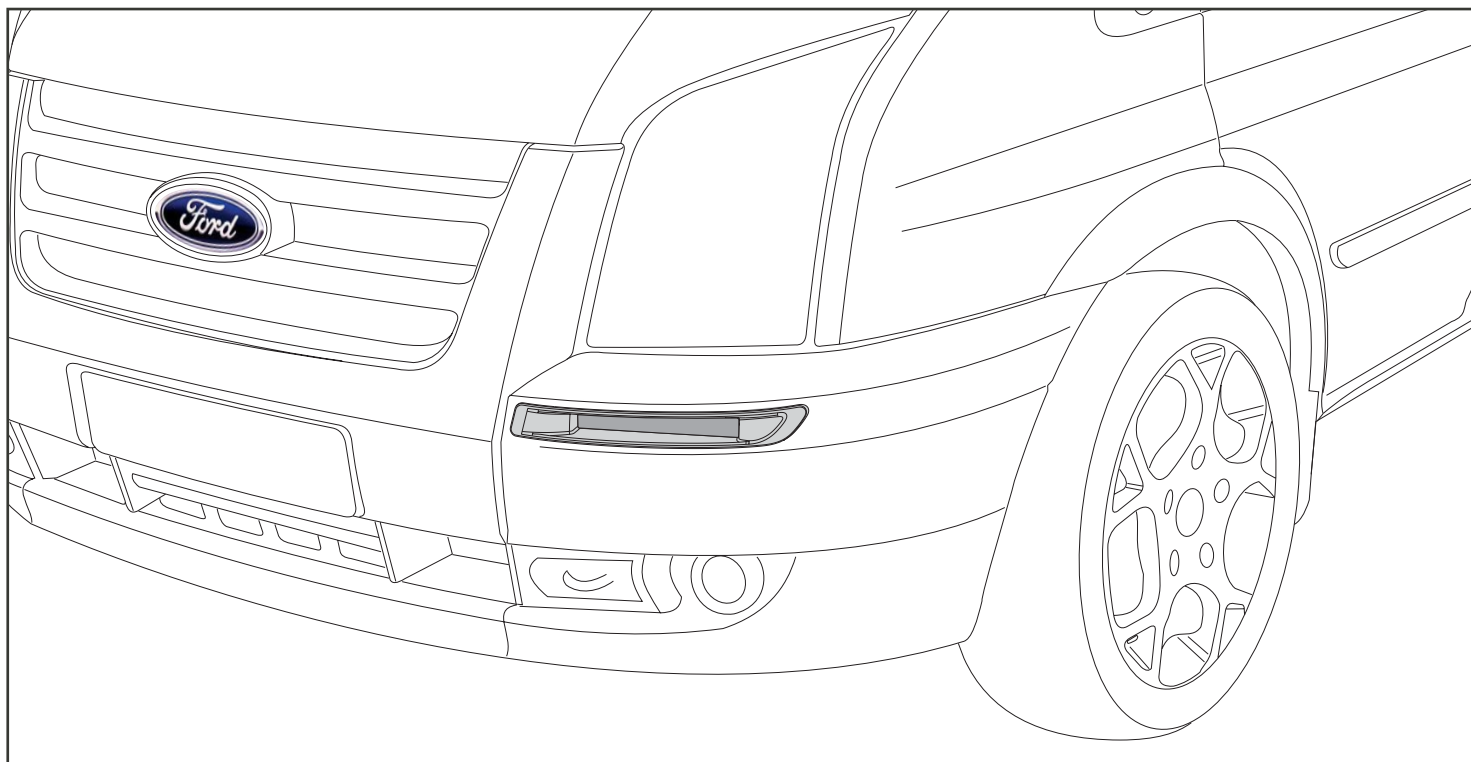

Stand vom 20.05.10 / Version 2.1

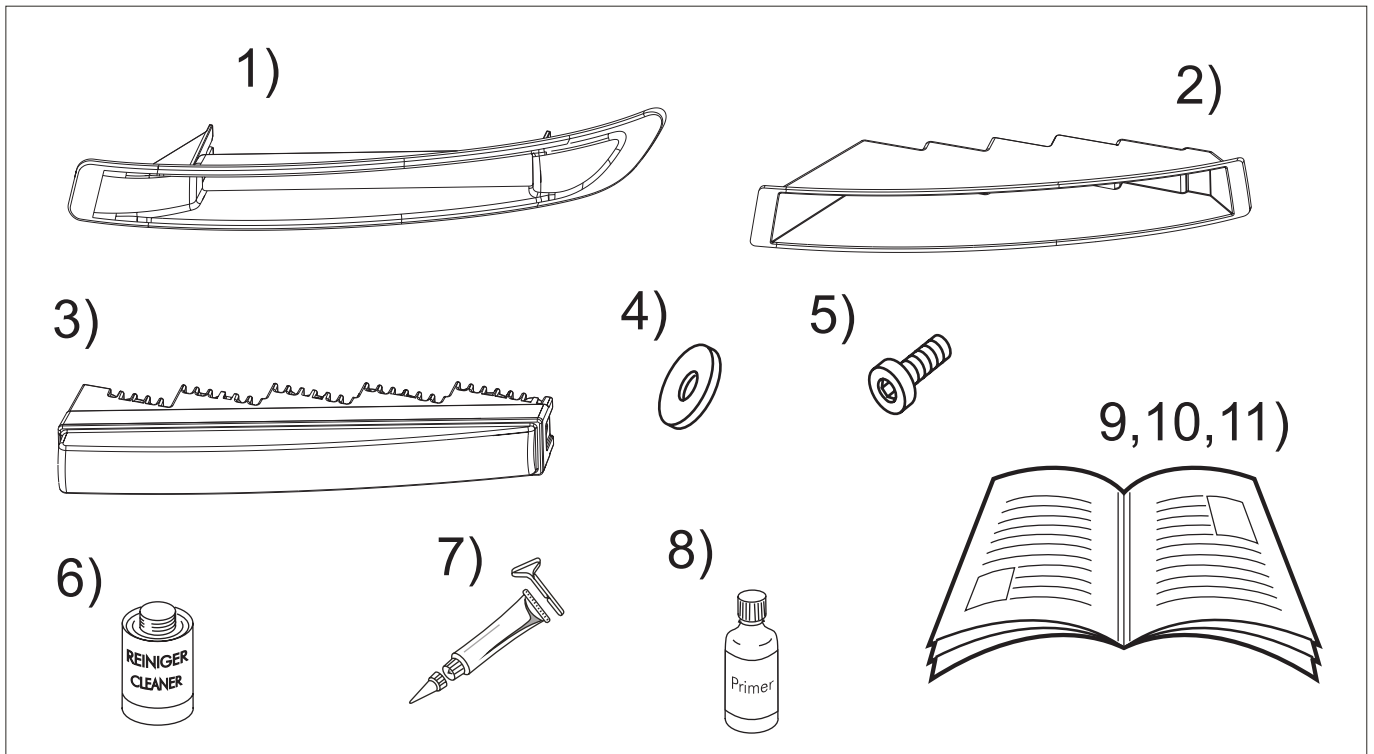

D

Stückliste:

Pos.	Bezeichnung	Anzahl
1.	Rahmen Aussenteil	2x
2.	Rahmen Innenteil	2x
3.	Tagfahrleuchte	2x
4.	Beilagscheibe	8x
5.	Schraube M6x10	8x
6.	Elch 205 Reiniger	1x
7.	1 K-PU-Kleber 80ml	1x
8.	Primer	1x
9.	Anschlussplan	1x
10.	Klebeanleitung	1x
11.	Montageanleitung	1x

GB

Prats list:

Item. Description	Quantity
1. Frame outpart	2x
2. Frame innerpart	2x
3. Daytime running lights	2x
4. Washer	8x
5. Screw M6x10	8x
6. Elch 205 cleaner	1x
7. 80ml component PU adhesive	1x
8. Primer	1x
9. Connecting diagram	1x
10. Adhesive instructions	1x
11. Fitting instructions	1x

D

Bitte die Montageanleitung vor Beginn sorgfältig lesen.

Wir empfehlen die Montage in einer Fachwerkstatt durchführen zu lassen.

Empfehlung: Das Anbauteil ist passgenau gearbeitet.
Trotzdem sollte **vor** dem Montieren ein Probeverbau gemäß dieser Montageanleitung vorgenommen werden.

I

Prima di iniziare il lavoro si prega di leggere attentamente le istruzioni di montaggio.

Raccomandiamo di far eseguire il montaggio in una officina specializzata.

Raccomandazione: Il componente di montaggio è un pezzo di alta precisione ed è già verniciato con uno strato di fondo. Nonostante ciò si raccomanda di eseguire **prima** del montaggio finale un montaggio di prova seguendo le indicazioni riportate nelle presenti istruzioni di montaggio.

E

Antes de comenzar, sírvase leer atentamente las instrucciones de montaje.

Les recomendamos efectuar el montaje en un taller especializado.

Recomendación: La pieza adosada está mecanizada con precisión de ajuste y ya está imprimada.
A pesar de ello deberá realizar un montaje de prueba según estas instrucciones de montaje **antes** de efectuar el montaje.

GB

Please read fitting instructions thoroughly before commencing installation.

We recommend that fitting is carried out by a specialist workshop.

Recommendation: The body part is precision manufactured and pre-primed. However, trial fitting should still be carried out in accordance with these fitting instructions **before** mounting.

NL

De montagehandleiding eerst zorgvuldig lezen!

Wij adviseren de montage door een vakgarage te laten uitvoeren.

Advies: Het montageonderdeel heeft de juiste pasvorm en is al geground. Niettemin raden wij aan **voor** het steun een montagetest volgens de montagehandleiding uit te voeren.

CZ

Před začátkem si laskavě přečtěte montážní návod!

Doporučujeme nechat montáž provést v odborné dílně.

Doporučení: Montážní díl je lícovaní zpracovaný a už natøen základním nátírem. Presto byste mil před montáž provést podle tohoto montážního návodu montáž na zkoušku.

F

Lire attentivement la notice de montage avant de commencer.

Nous recommandons de confier le montage à un professionnel.

Recommandation : La pièce est fabriquée aux bonnes cotes et déjà apprêtée. Nous vous recommandons toutefois d'effectuer un essai de pose suivant la présente notice de montage **avant** la montage.

S

Var vänlig läs monteringsanvisningen noggrant innan du börjar.

Vi rekommenderar att du genomför monteringen i en fackverkstad.

Rekommendation: Tillbehörsdelen är exakt tillverkad och redan grundad. Trots detta bör du göra en provmontering enligt monteringsanvisningen **före** monteringen.

J

まず取扱説明書を最後までよくお読みください。

取付けは専門修理工場で行うことを推奨いたします。

推奨: 取付け部品はぴったり合うように正確な寸法で仕上げられ、すでに下塗りされていますが、それでも塗装前に本取扱説明書に従って仮取付けを行ってください。

Symbole / symbols

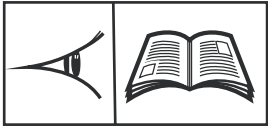

siehe Werkstattbuch/ Lackieranleitung
see workshopbook/ painting specifications

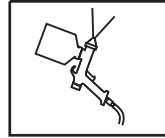

lackieren
paint



mit weichem Tuch reinigen
clean with soft cloth

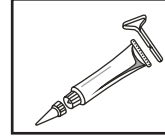

Kleber
adhesive

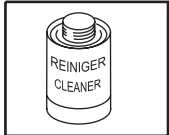

Reiniger
cleaner

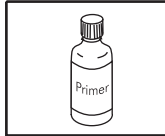

Primer
primer



Klebeband
tape



anschleifen
grind

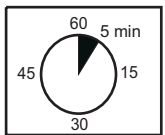

Ablüftzeit
ventilating time

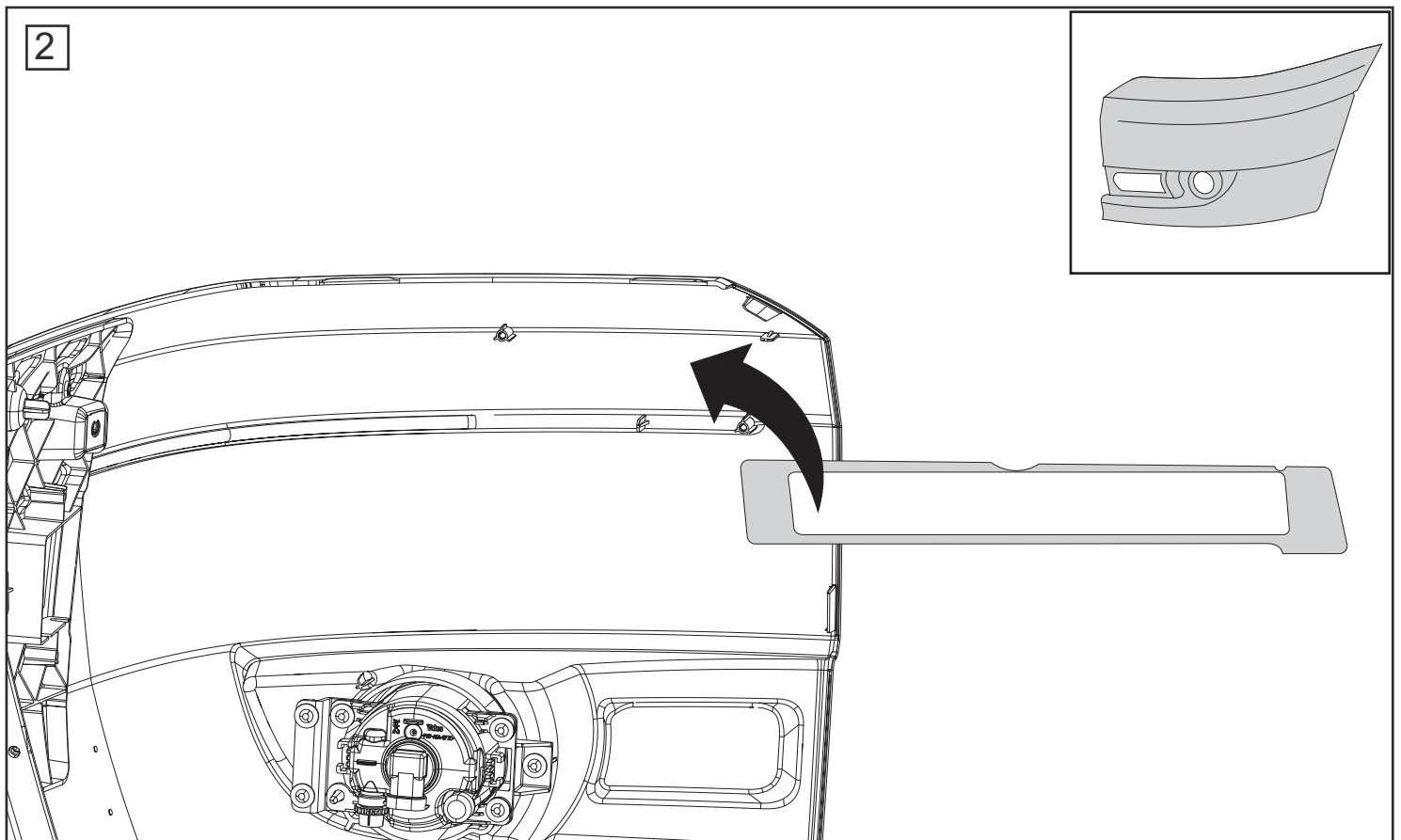
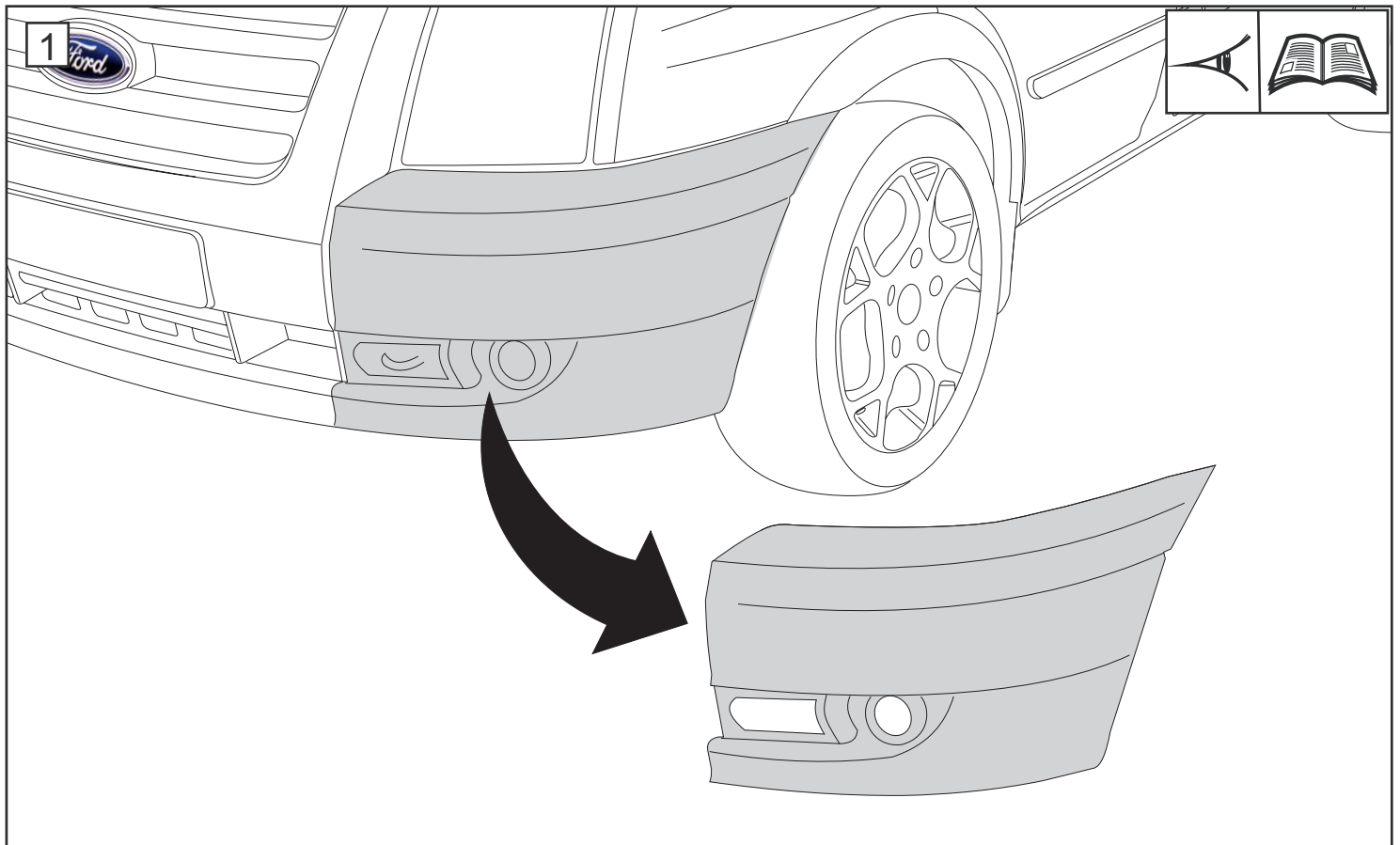

3

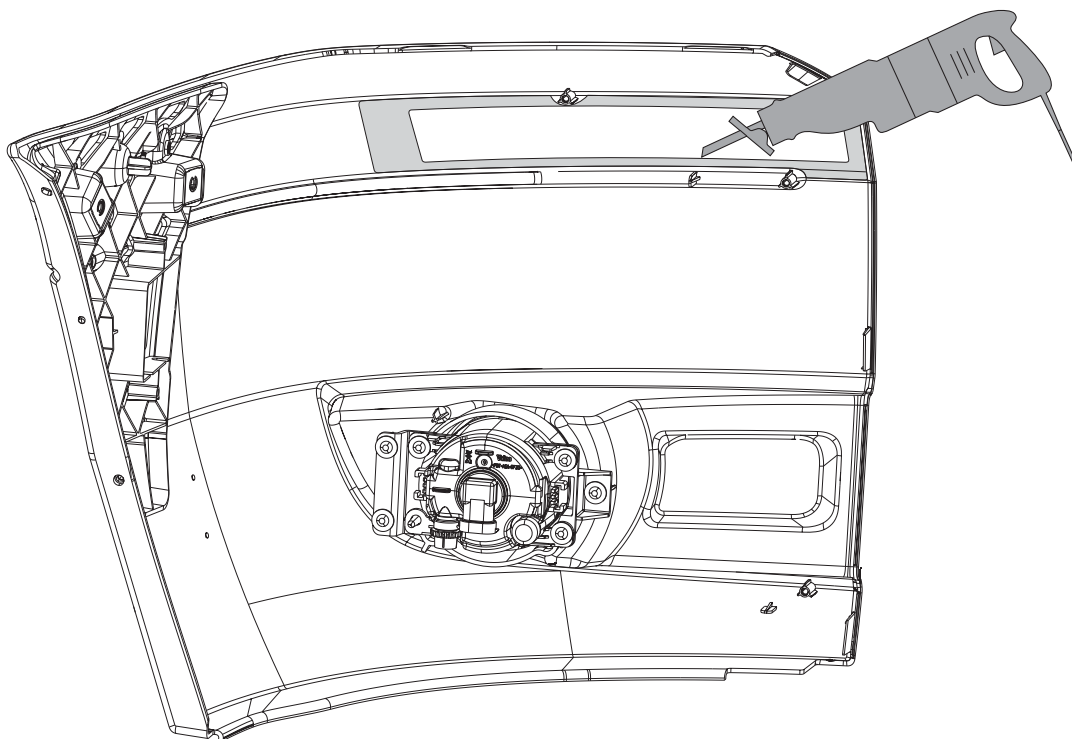

4

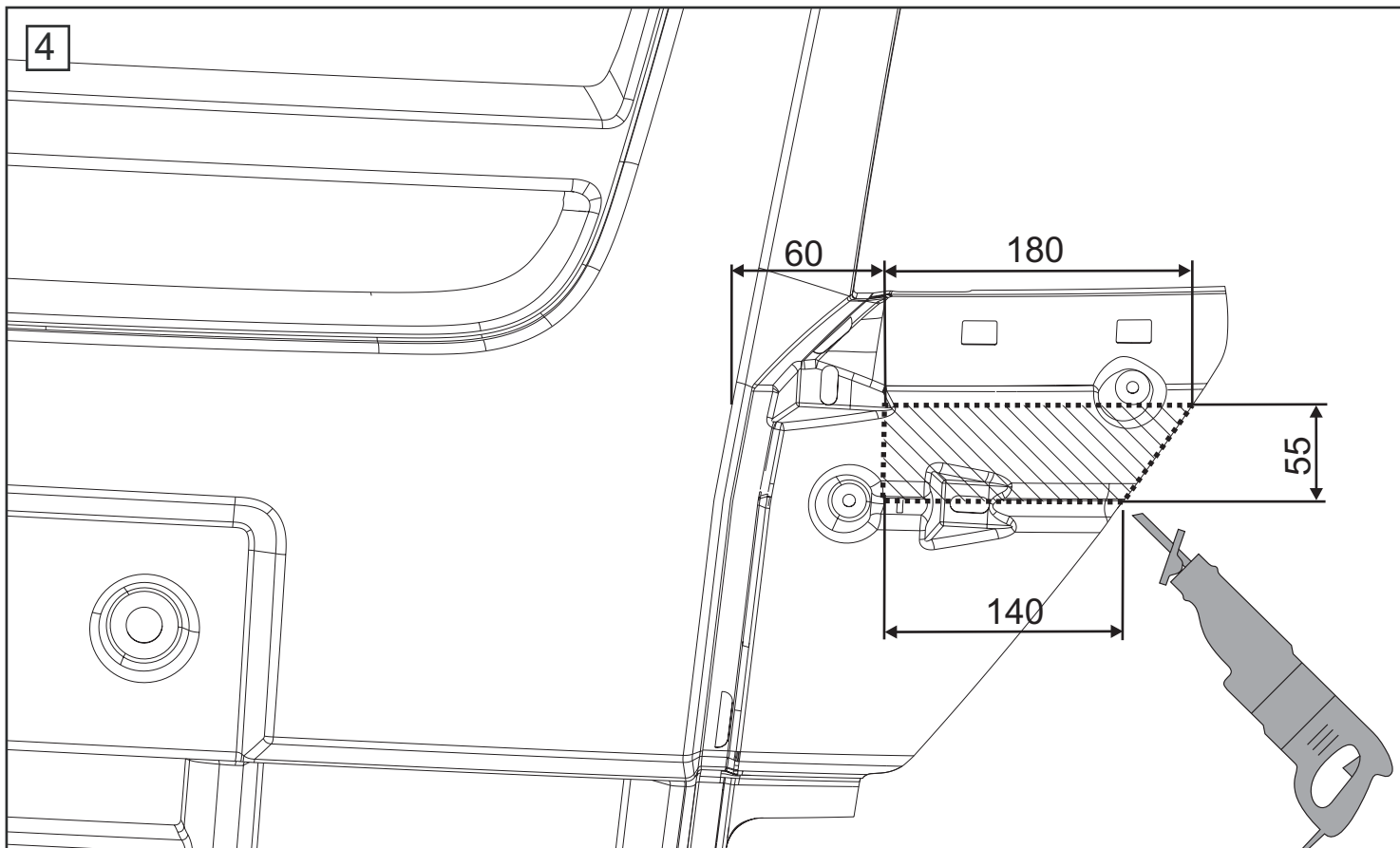

5

1.)



2.)

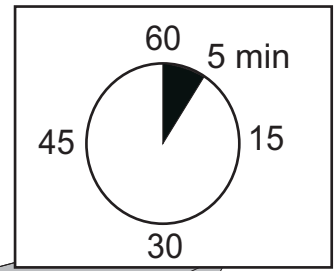
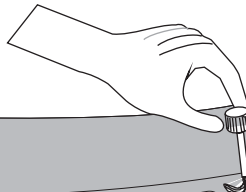

6

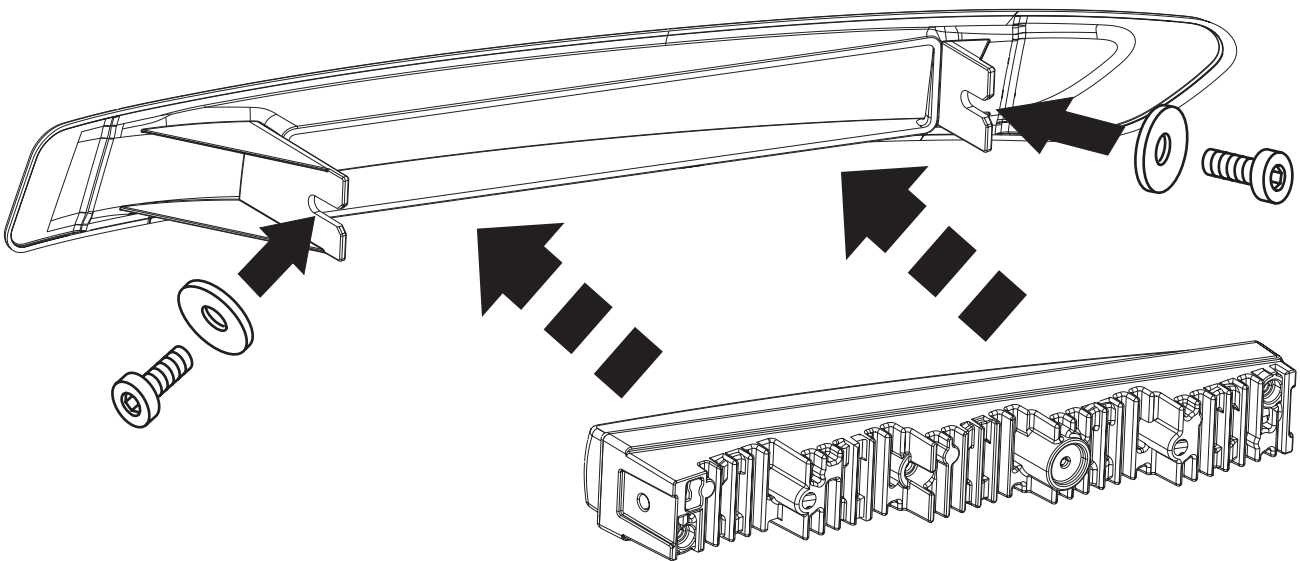

7

2.)

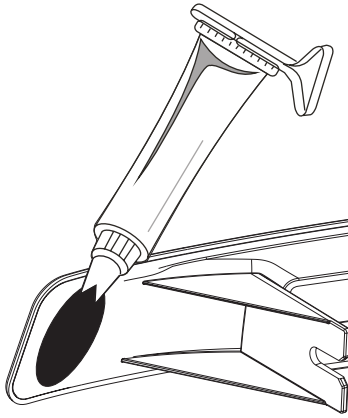

1.)

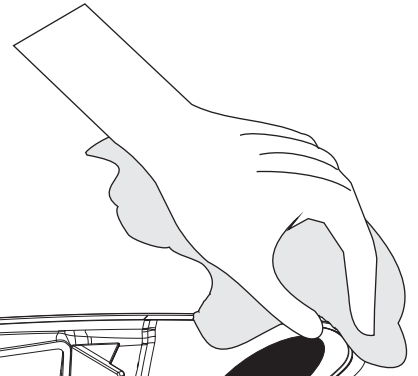

8

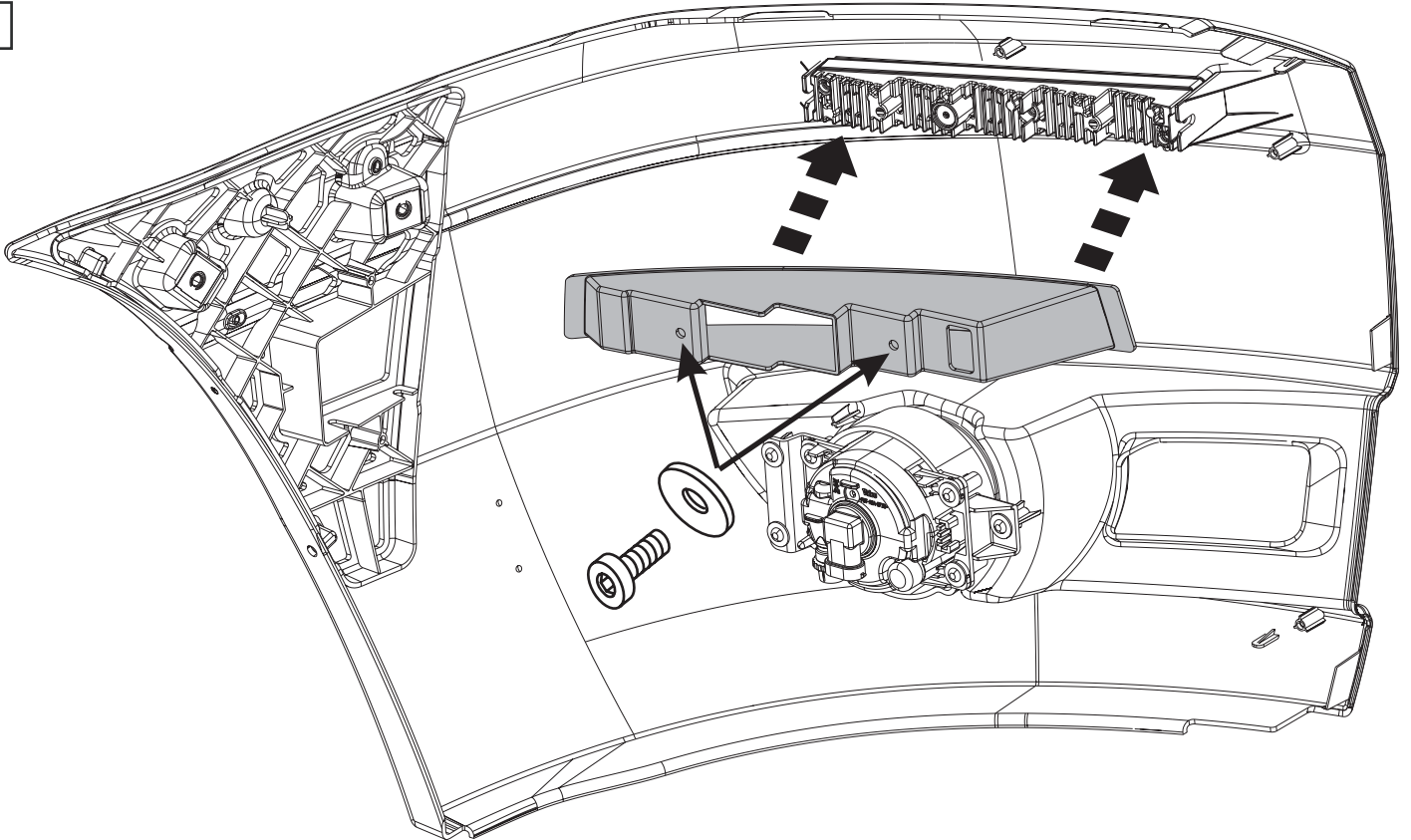

9

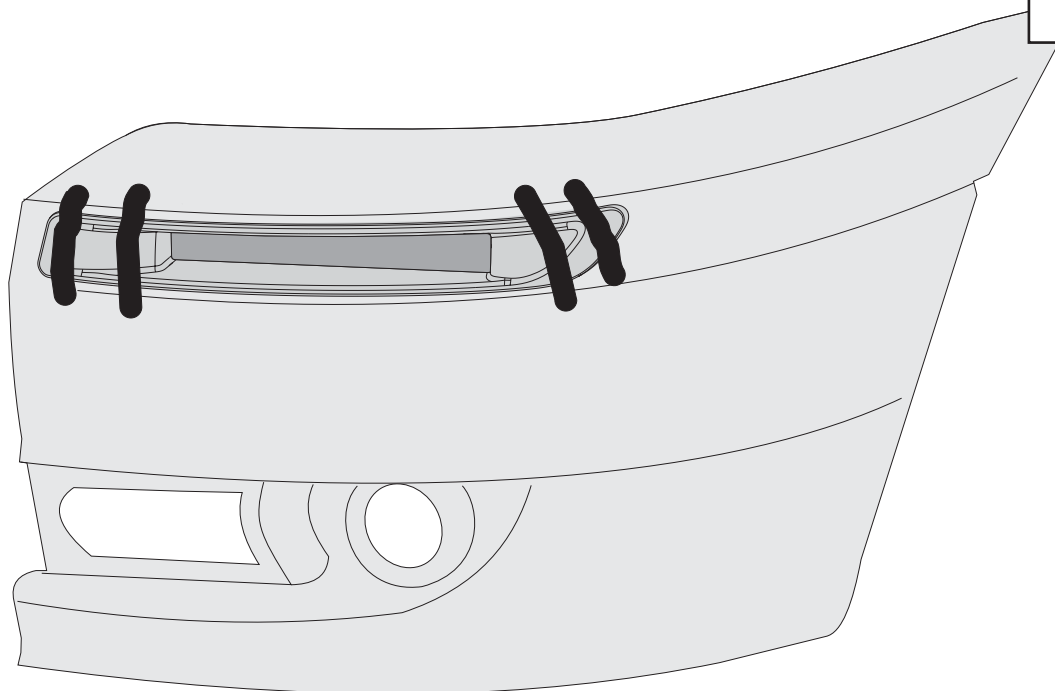

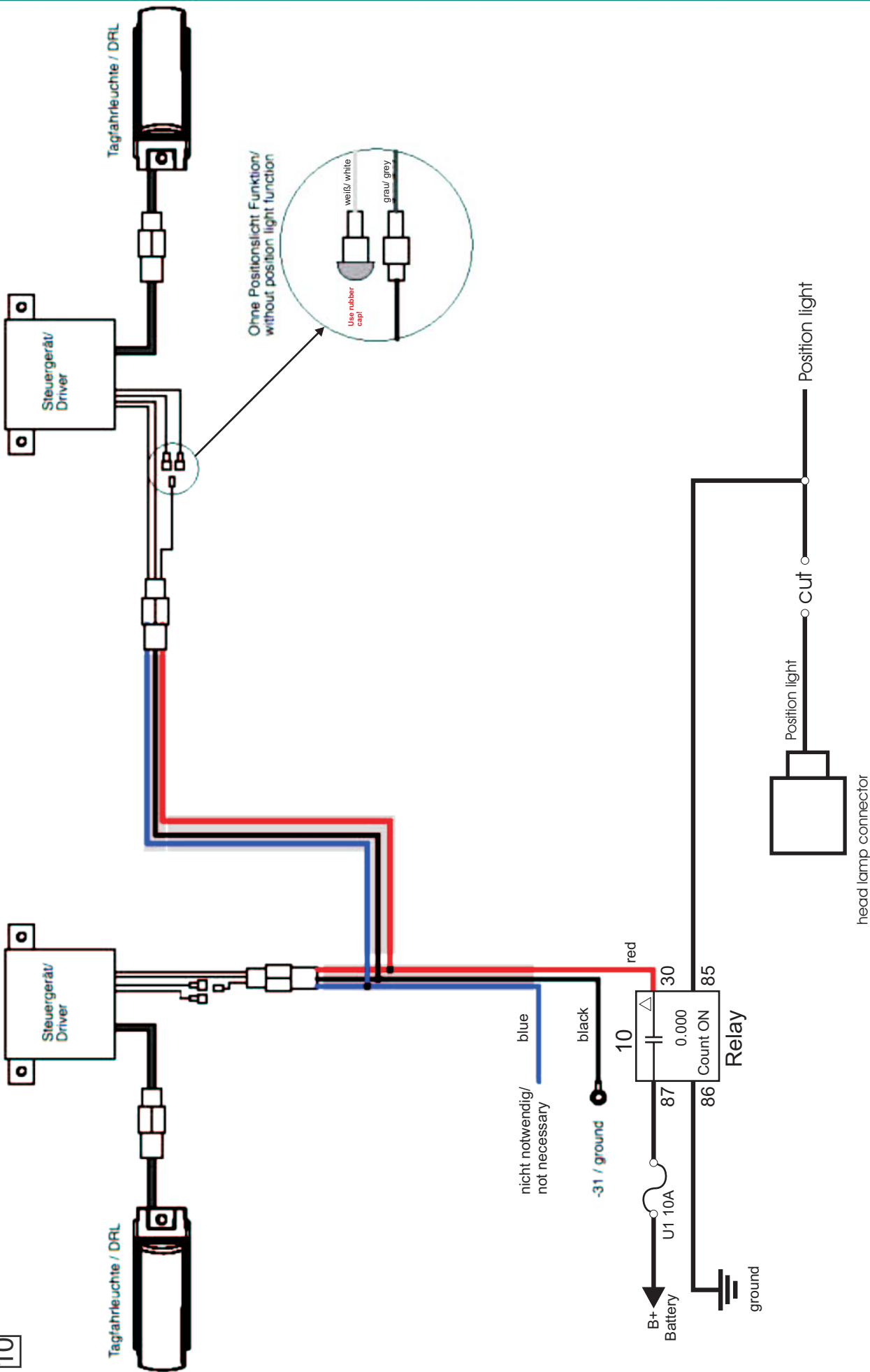

(Relay is not included in delivery)

NOTE: We recommend soldering!

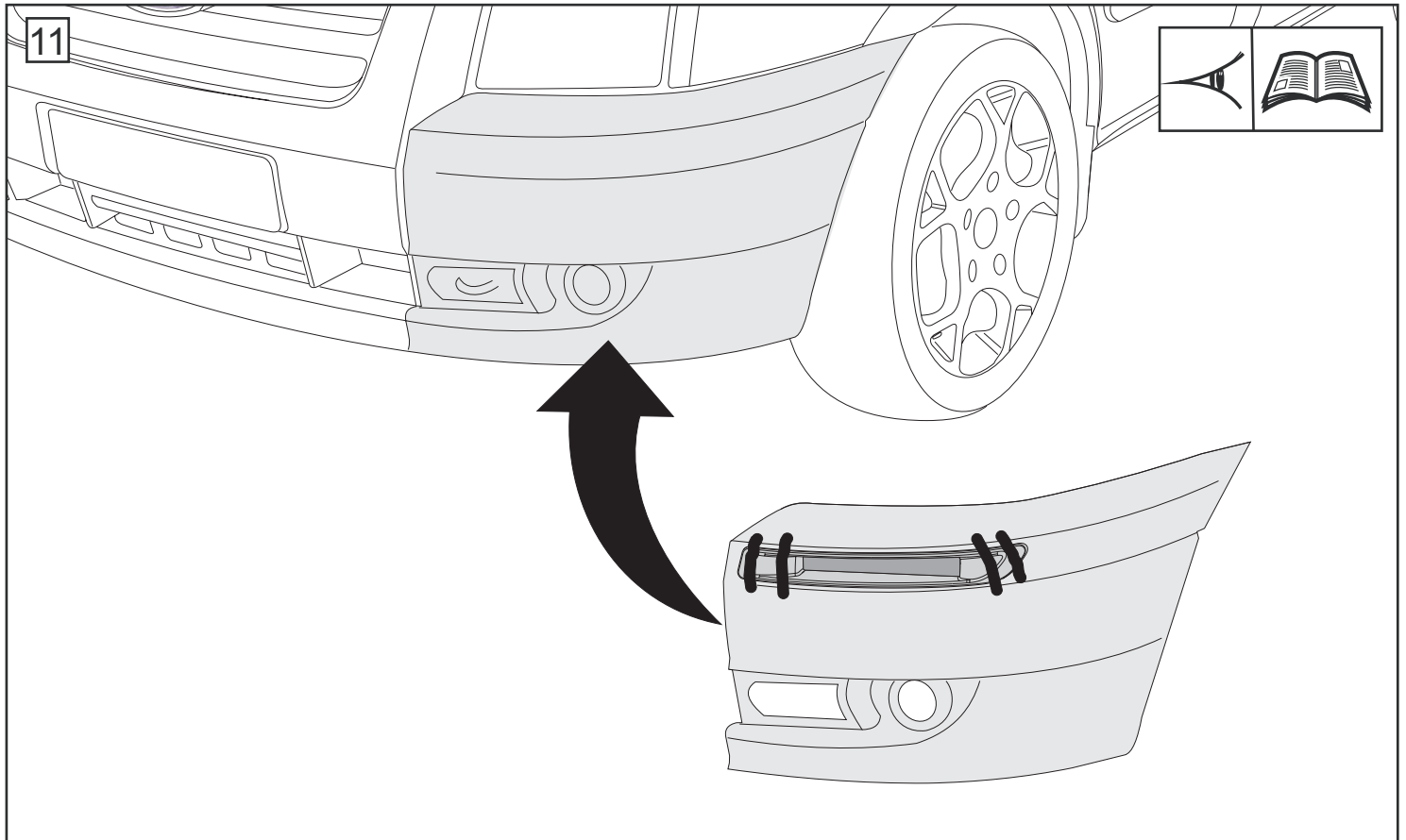

D

Das Anbauteil darf erst nach 24h mechanisch beansprucht werden!
 Erst nach 48h ist die komplette Abluftzeit des Elch Klebers erreicht und Waschbeständig!

GB

Do not make any mechanical use of the part within 24 hours!
 The total exhaust time of the elch glue is 48 hours, and only after that time the car can be washed!

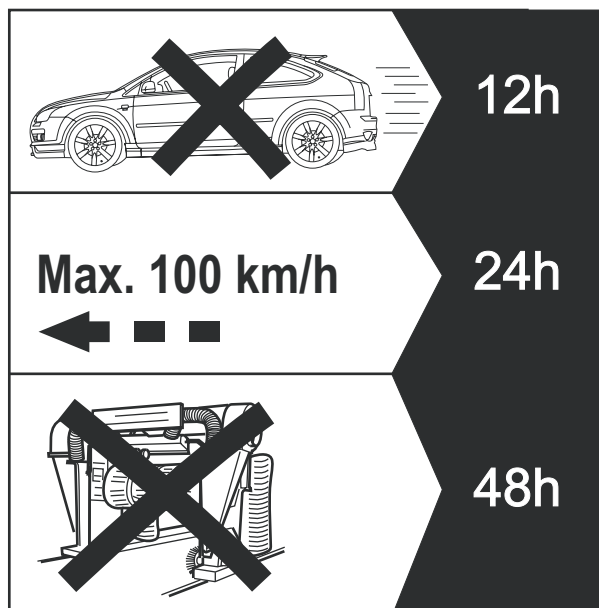



Scope of supply

- 2x LED-Day time running light (black or clear)
- 2x control units for the LED-Day time running light & position light
- 1x harness
- 4x screws M6 stainless steel
- 1x user manual
- boxed

