

| | |
|-----------|--|
| GB | INSTALLATION INSTRUCTION ROOF SPOILER |
| D | EINBAUANLEITUNG DACHFLÜGEL |
| E | INSTRUCCIONES DE MONTAJE SPOILER DE TECHO |
| F | NOTICE DE MONTAGE SPOILER DE TOIT |
| I | ISTRUZIONI DI MONTAGGIO SPOILER SUL TETTO |
| P | INSTRUÇÕES DE MONTAGEM DEFLECTOR DE AR DE TAJADILHO |
| NL | INBOUW-INSTRUCTIE DAK SPOILER |
| DK | MONTERINGSVEJLEDNING TAG SPOILER |
| N | MONTERINGSVEILEDNING TAK SPOILER |
| S | MONTERINGSANVISNING TAK SPOILER |
| SF | ASENNUSOHJE KATTOSPOILERI |
| CZ | NÁVOD K MONTÁŽI STŘEŠNÍ SPOILER |
| H | BESZERELÉSI UTASÍTÁS TETŐSPOILER |
| PL | INSTRUKCJA INSTALOWANIA SPOILER DACHOWY |
| GR | Οδηγίες Τοποθέτησης Σπόιλερ οροφής |



© Copyright MS-Design 2005

Printed Copies are uncontrolled

Expert Fitment Required

Montage durch Fachwerkstatt erforderlich

Montaje sólo por el concesionario

Montage par spécialiste nécessaire

E' necessario montaggio in officina specializzata

Especialista em montagem requerido

Montage door vakman nodig

Montage ved professionelt værksted påkrævet

Nødvendig med montering fra fagværksted

Verkstadsmontage erfordras

Asennus tarpeen merkkikorjaamossa

Montáž ve specializované dílni nutná

A szereléshez szakműhely kell

Konieczny montaz przez warsztat specjalistyczny

Να τοποθετεί απο συνεργείο

Subject to alteration without notice

Technische Änderungen vorbehalten

Reservadas modificaciones técnicas

Sous réserve de modifications techniques

Con riserva di apportare modifiche tecniche

Reservamo-nos o direito a alterações técnicas

Technische wijzigingen voorbehouden

Med forbehold for tekniske ændringer

Tekniske forendringer forbeholdes

Med reservation för tekniska ändringar

Tekniset muutokset pidätetään

Technické zmeny vyhrazeny

A változtatások technika jogát fenntartjuk

Zmiany techniczne zastrzeżone

Επιόλασσομεθα για αλλαγές

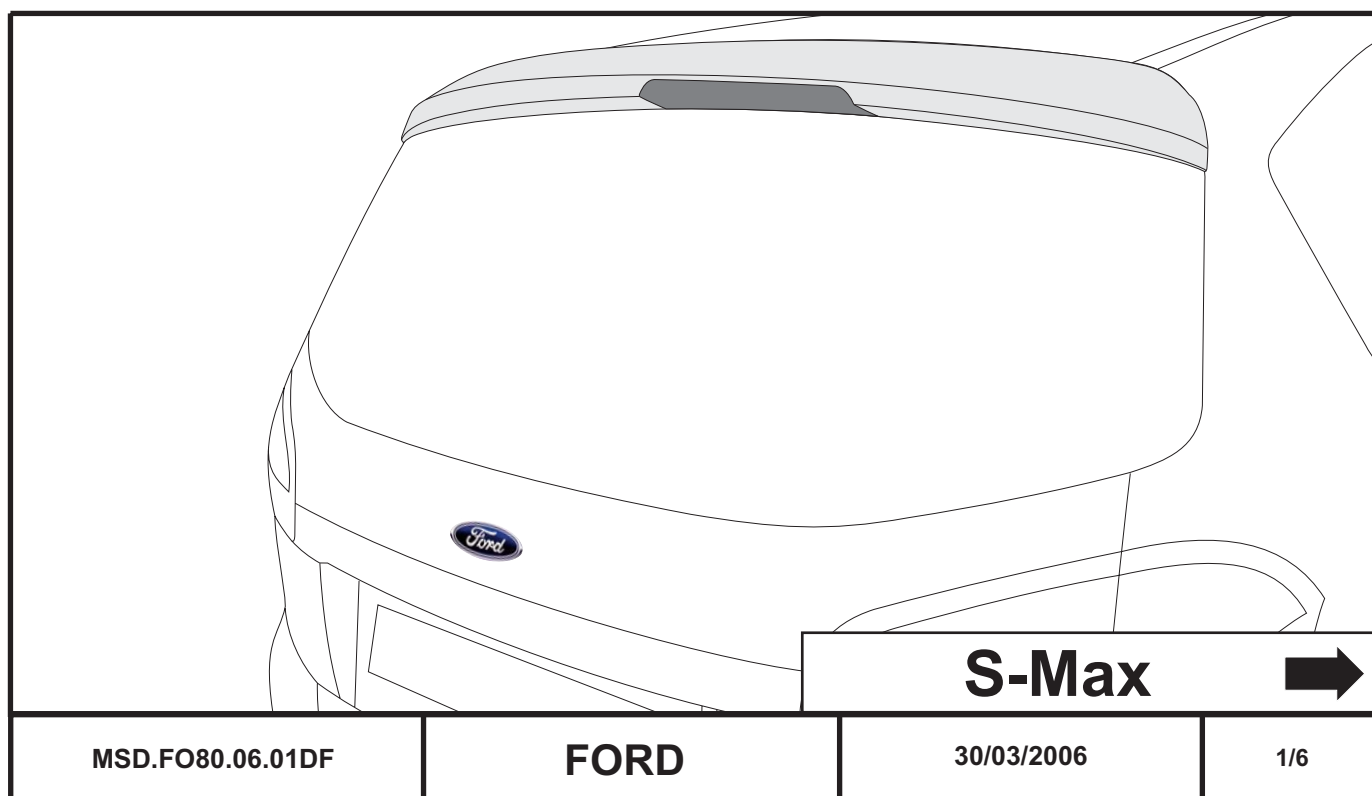

S-Max



MSD.FO80.06.01DF

FORD

30/03/2006

1/6

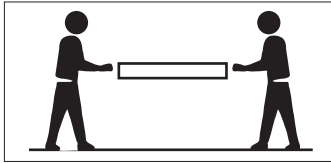

- (GB) 2 Man Operation Required
- (D) Nur zu zweit ausführen
- (E) Realizar sólo entre dos personas
- (F) Toujours s'y mettre de deux
- (I) Da eseguire soltanto in due
- (P) Executar somente a dois
- (NL) Met 2 personen uitvoeren
- (DK) Skal udføres af to personer
- (N) Må utføres av to personer
- (S) Utförs endast av två personer
- (SF) Tehtävä kahdestaan
- (CZ) Provádít jen ve dvou
- (H) Csak két személy végezheti el
- (PL) Wykonywać tylko w dwie osoby
- (GR) 2 Λειτουργία ατόμων που απαιτείται

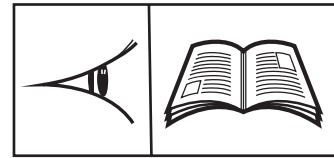



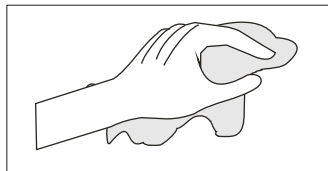





- (GB) see workshopbook
- (D) siehe Werkstattbuch
- (E) vea el libro del taller
- (F) regardez à livre d'atelier
- (I) veda il libro dell'officina
- (P) vea a livro d'oficina
- (NL) zie workshopboek
- (DK) se værkstedsbog
- (N) se verkstedbok
- (S) se verkstadsboken
- (SF) zie workshopboek
- (CZ) vis manuál dílenský
- (H) lásd kézikönyv javítóműhely
- (PL) patrz manual warsztat
- (GR) δείτε το βιβλίο εργαστηρίων

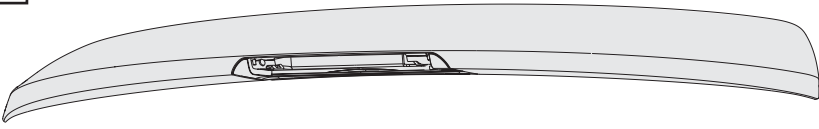

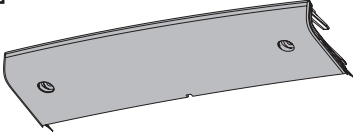
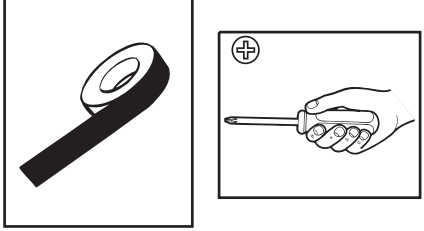
- (GB) clean and ventilate
- (D) reinigen und ablüften lassen
- (E) limpiar y ventilar
- (F) nettoyer et laisser sécher à l'air
- (I) pulire e far essiccare
- (P) limpar e arejar
- (NL) reinigen en laten afzuigen
- (DK) rengør og lad tørre
- (N) rengjøres og utluftes
- (S) rengör och låt lufta
- (SF) puhdistaa ja anna haihtua
- (CZ) vyčistit a nechat odvitrat
- (H) tisztítottassa meg és légteleníttesse
- (PL) wyczyścić i wysuszyć na powietrzu
- (GR) Καθαρίστε και αφήστε να στεγνώσει

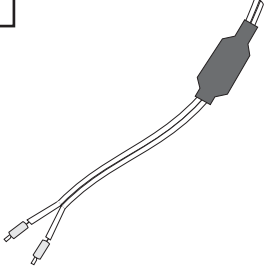
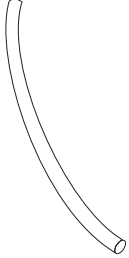
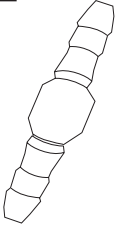
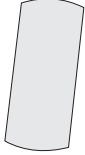
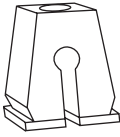
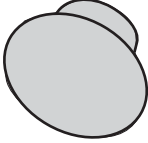

- (GB) tape
- (D) Klebeband
- (E) cinta adhesiva
- (F) ruban adhésif
- (I) nastro adesivo
- (P) fita adesiva
- (NL) Kleefband
- (DK) Klæbebånd
- (N) Klebeband
- (S) Klisterband
- (SF) Liimanauha
- (CZ) lepicí páska
- (H) ragasztószalag
- (PL) taśma klejąca
- (GR) Κολλητική ταινία

| | | | | | |
|--|--|---|--|--|--|
| A |  | | |  | |
| B | C | | | | |
|  | |  | | | |
| D | E | F | G |  | |
|  |  | 3,9x16  2x |  | | |
| H | I | J | K | L | M |
|  |  |  2x |  2x |  |  |

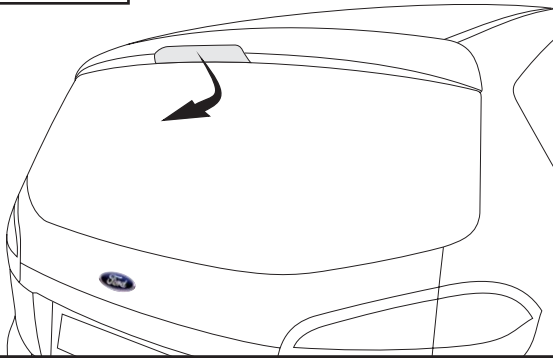
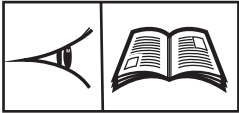

1



2

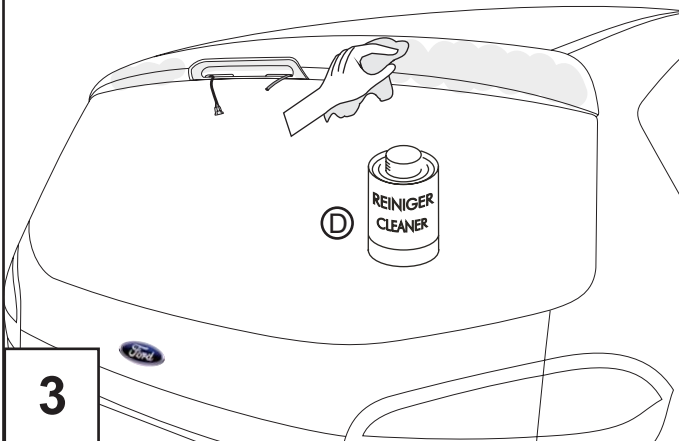

3

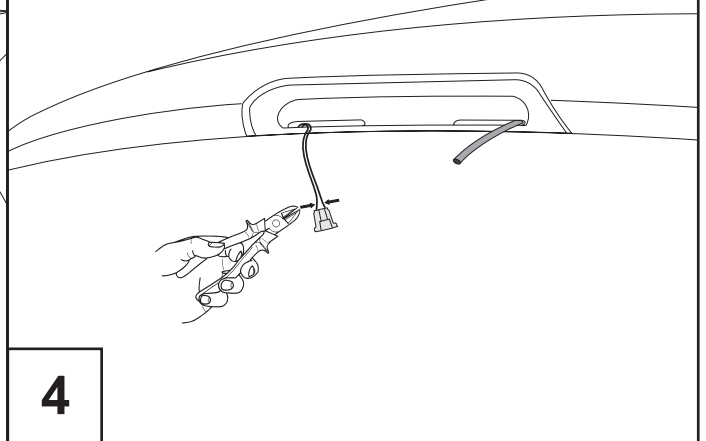

4

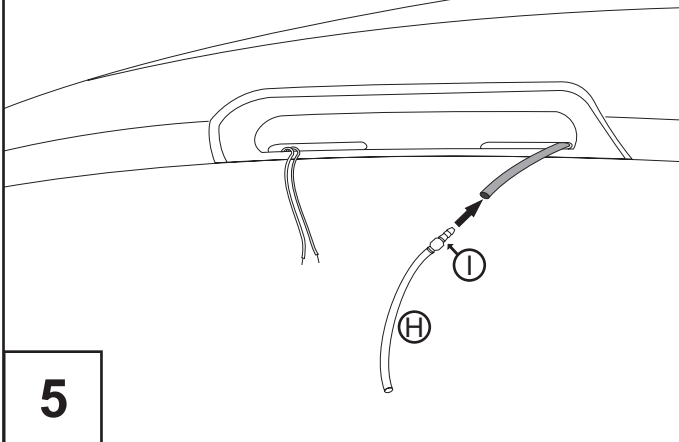

5

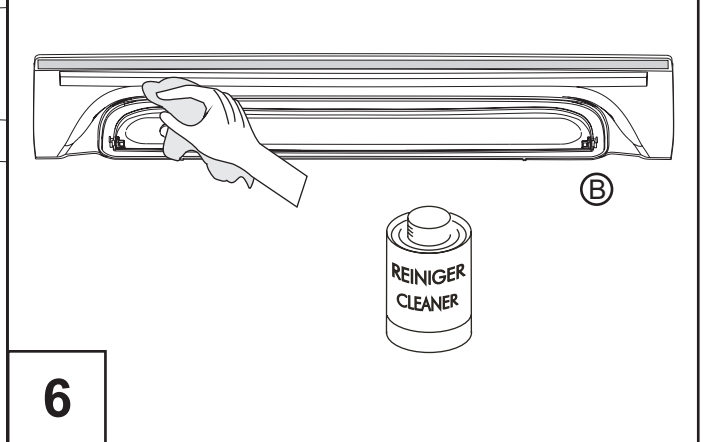

6

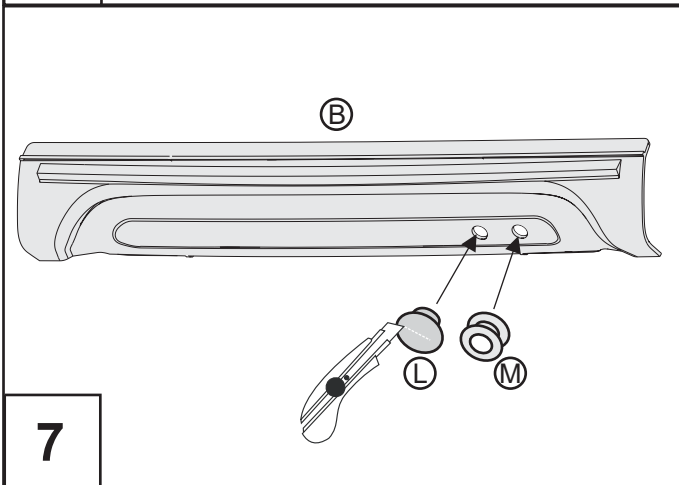

7

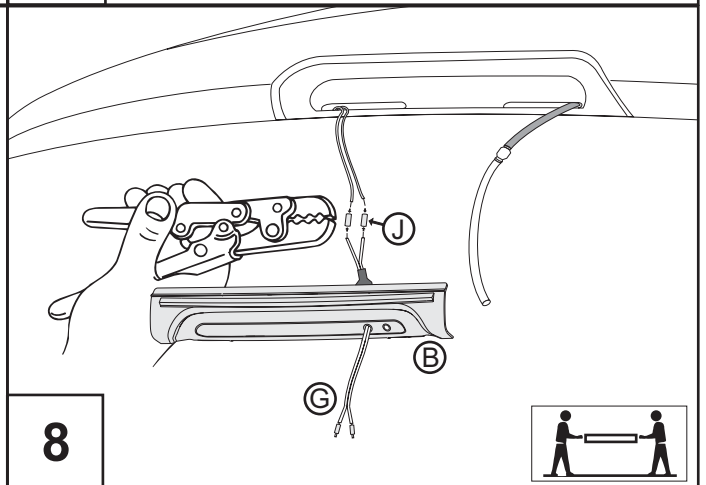

8



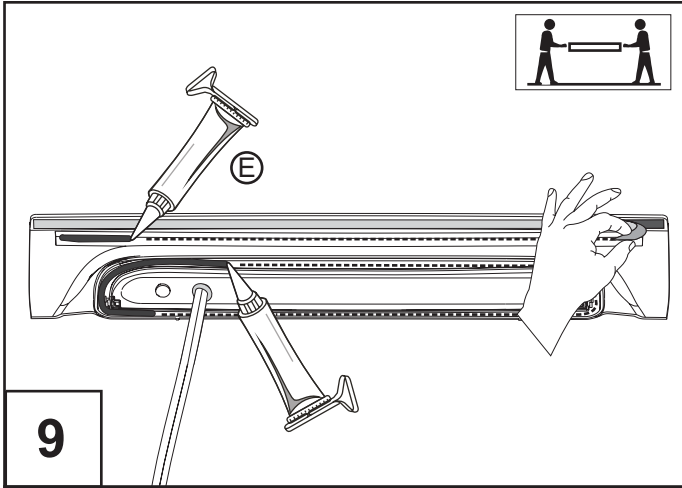

9

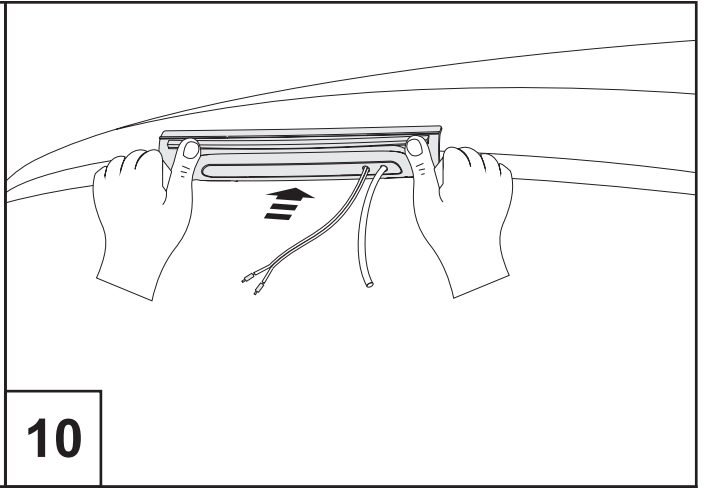

10

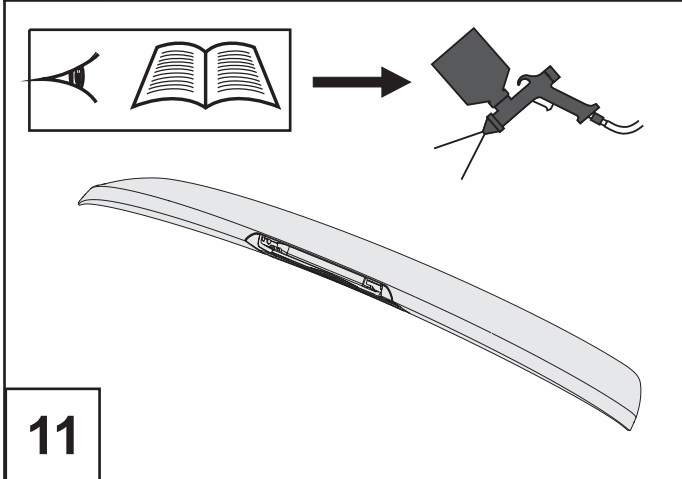

11

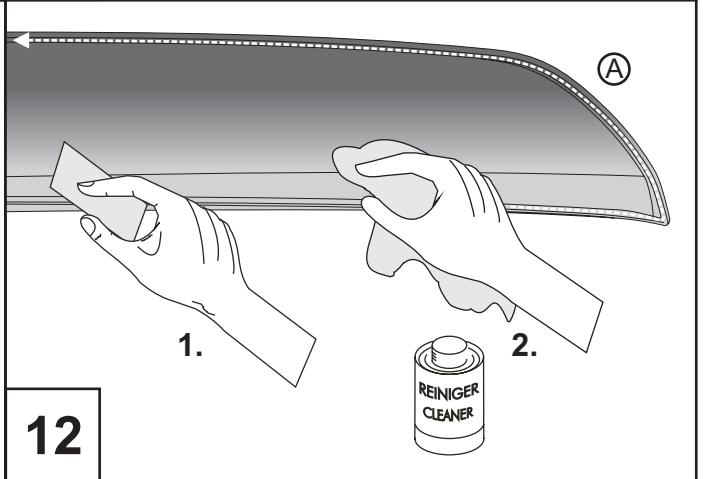

12

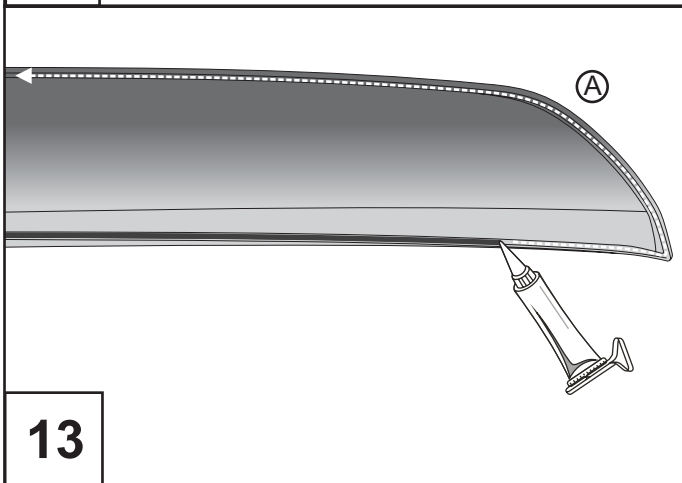

13

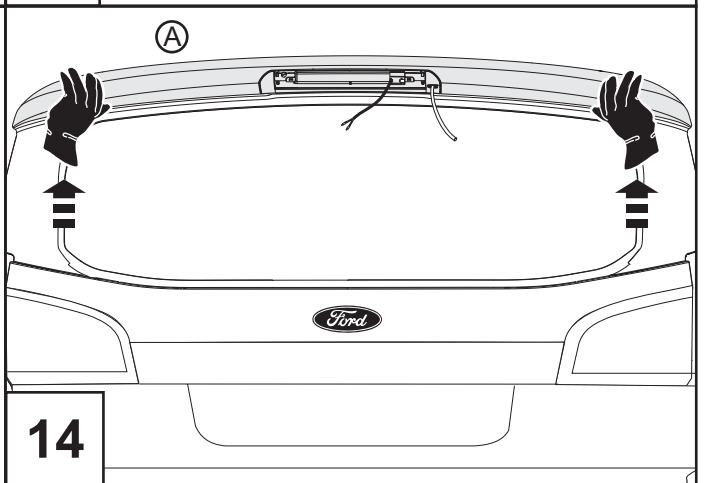

14

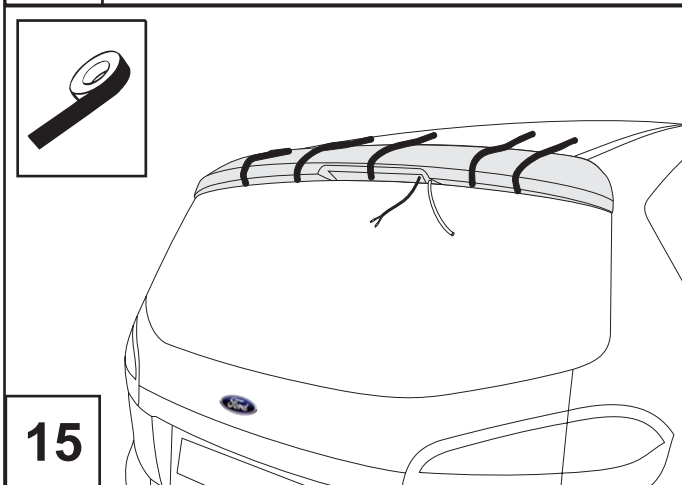

15

| | |
|-------------------|-----|
| | 12h |
| Max. 100 km/h | 24h |
| | 48h |

16

